

**HANDICAP MOUNTING SIGN DETAIL**  
NOT TO SCALE

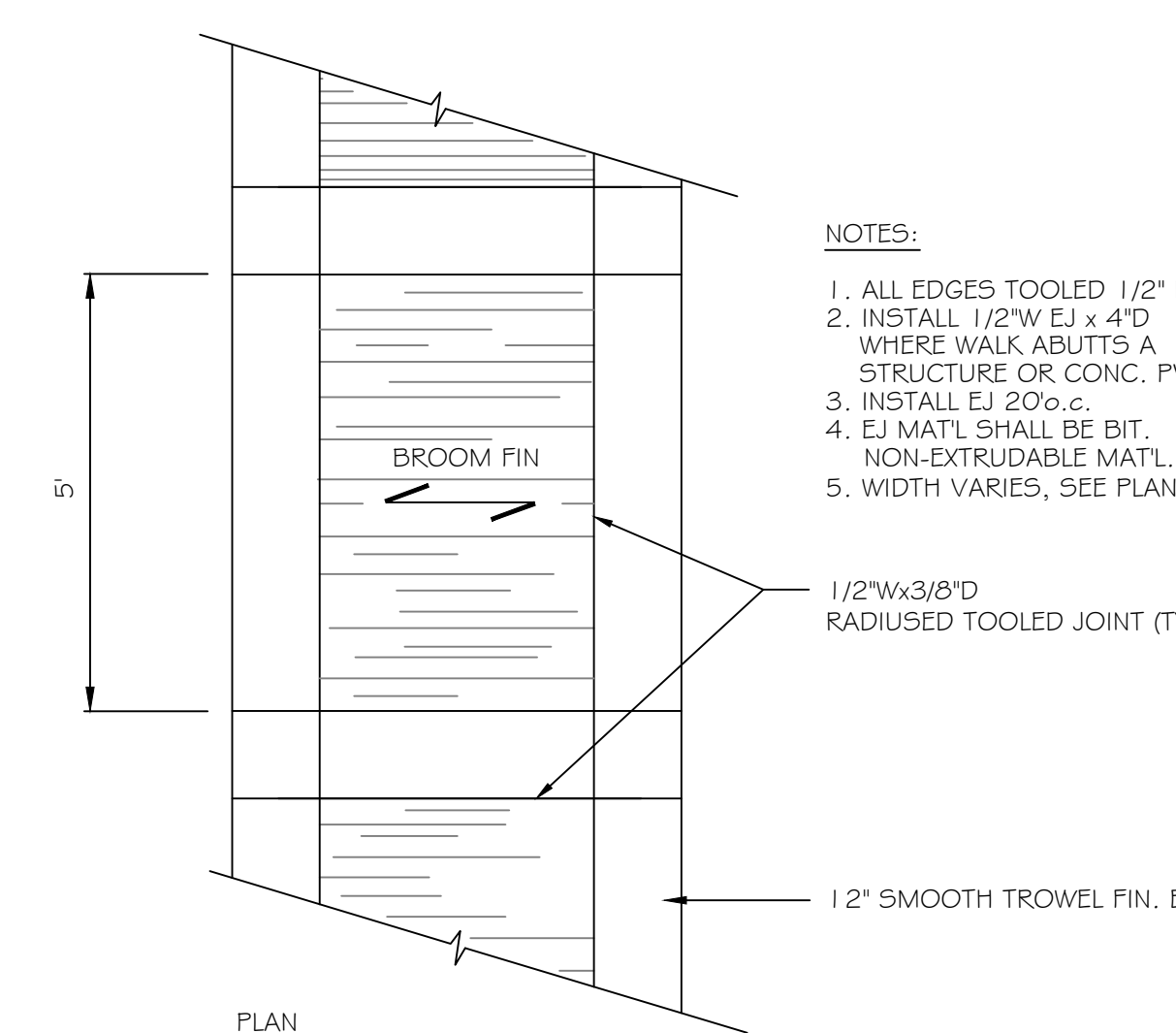

**CONCRETE WALK**  
NOT TO SCALE

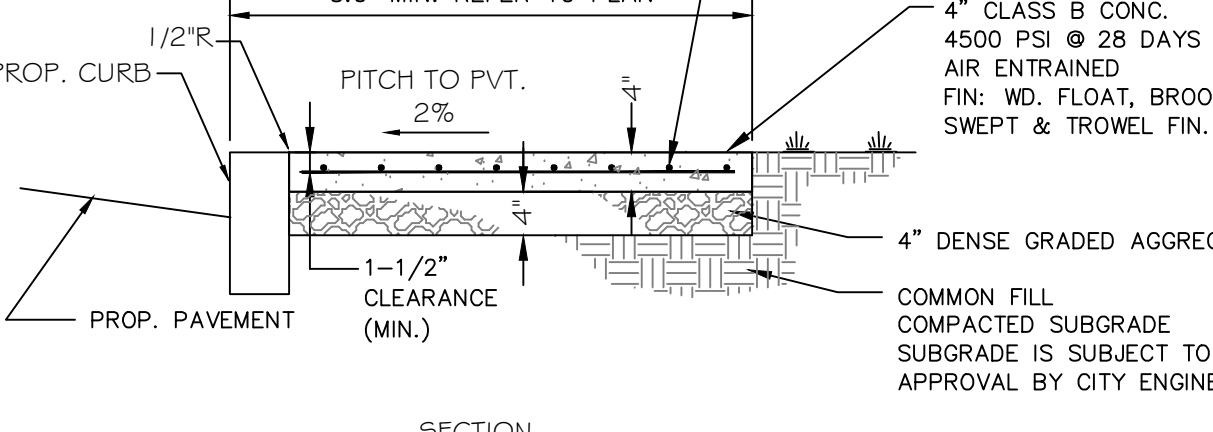

**GRAVEL SERVICE DRIVE DETAIL**  
NOT TO SCALE

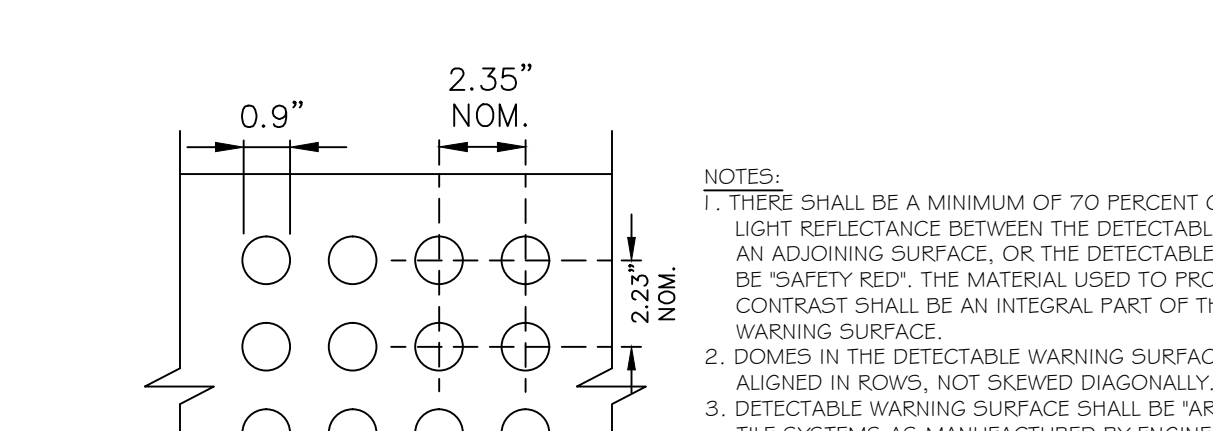

**DETECTABLE WARNING SURFACE DETAIL**  
NOT TO SCALE

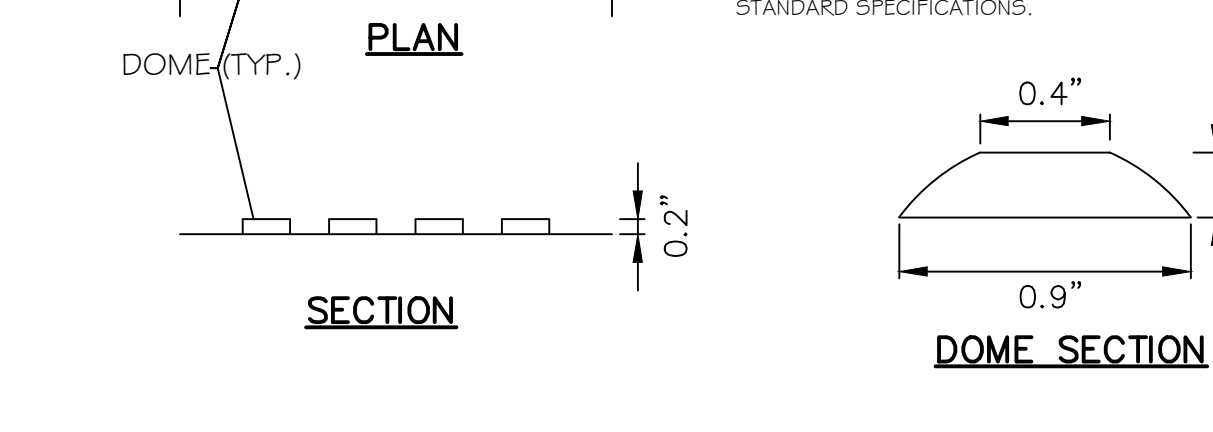

**HANDICAPPED RAMP DETAIL FOR CORNER OF SIDEWALK**  
NOT TO SCALE

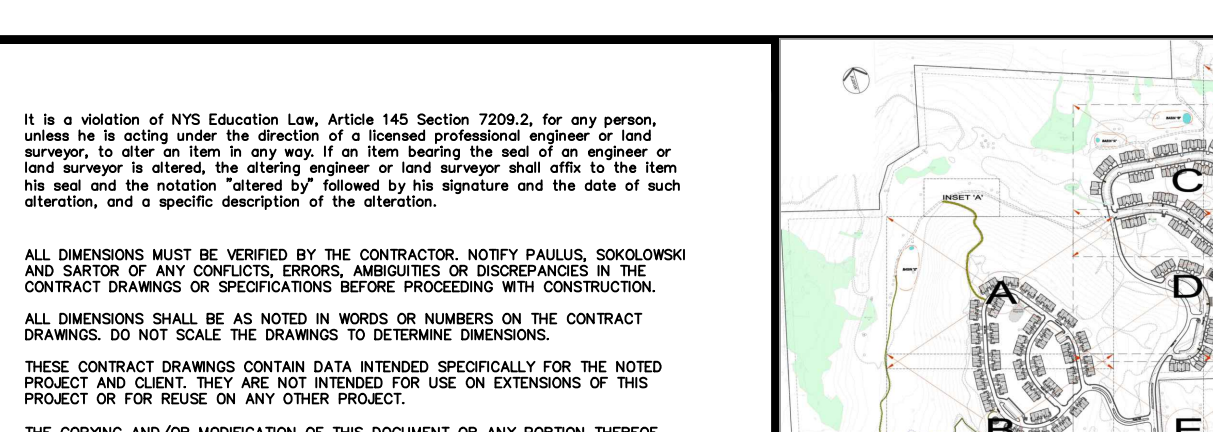

**HANDICAPPED RAMP/DEPRESSED CURB DETAIL**  
NOT TO SCALE

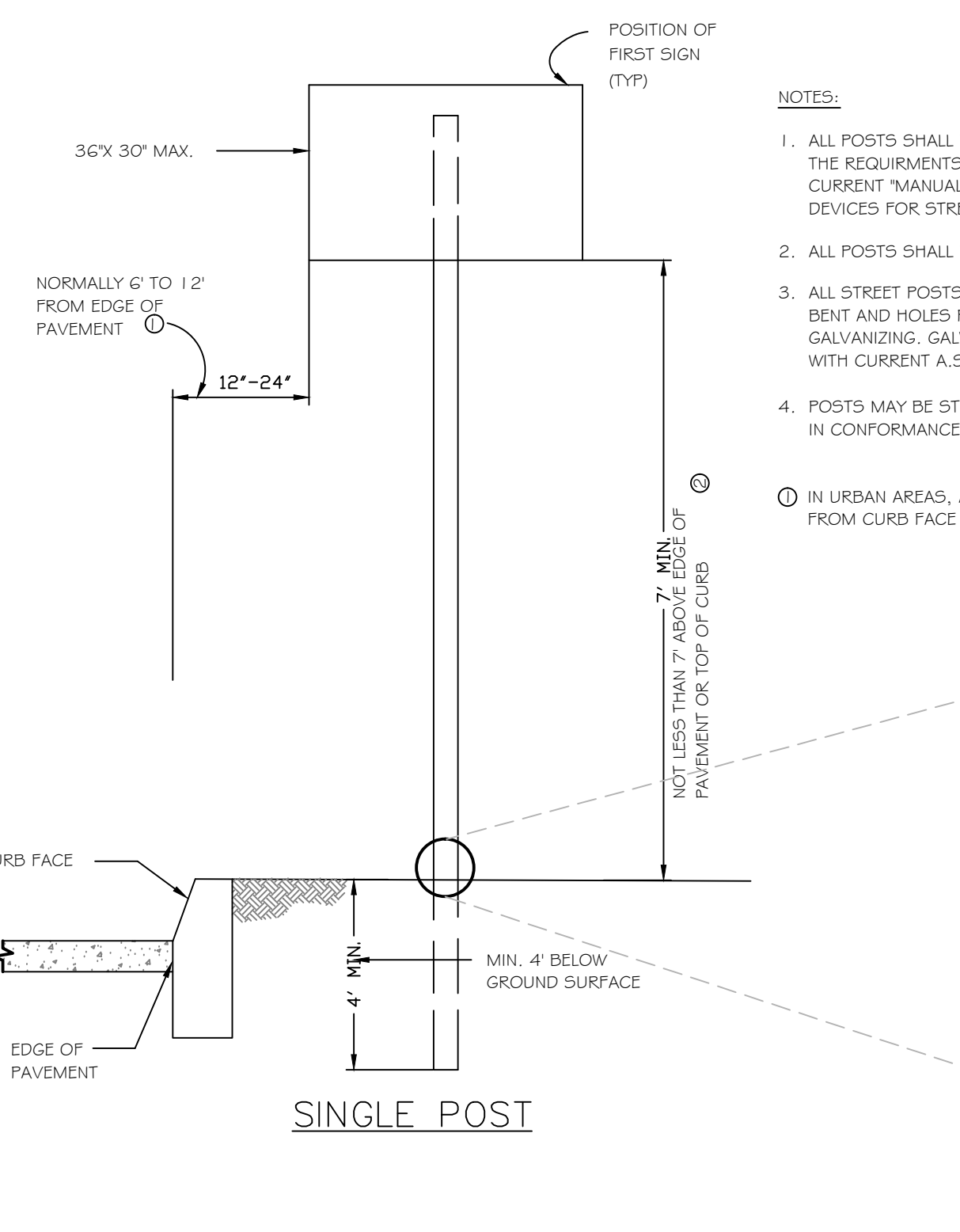

**SIGN MOUNTING DETAIL**  
NOT TO SCALE

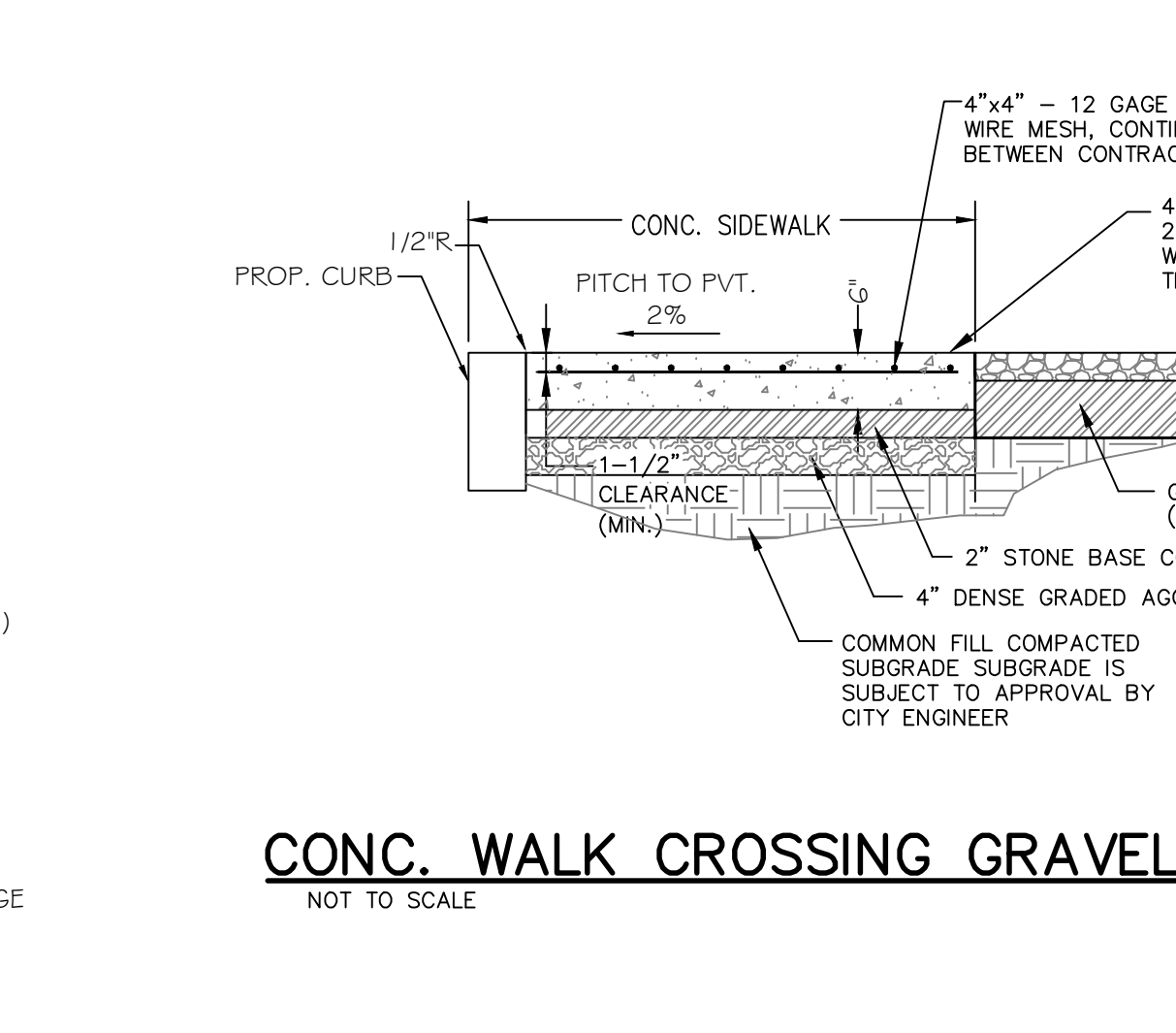

**TYPICAL CROSS WALK DETAIL**  
NOT TO SCALE

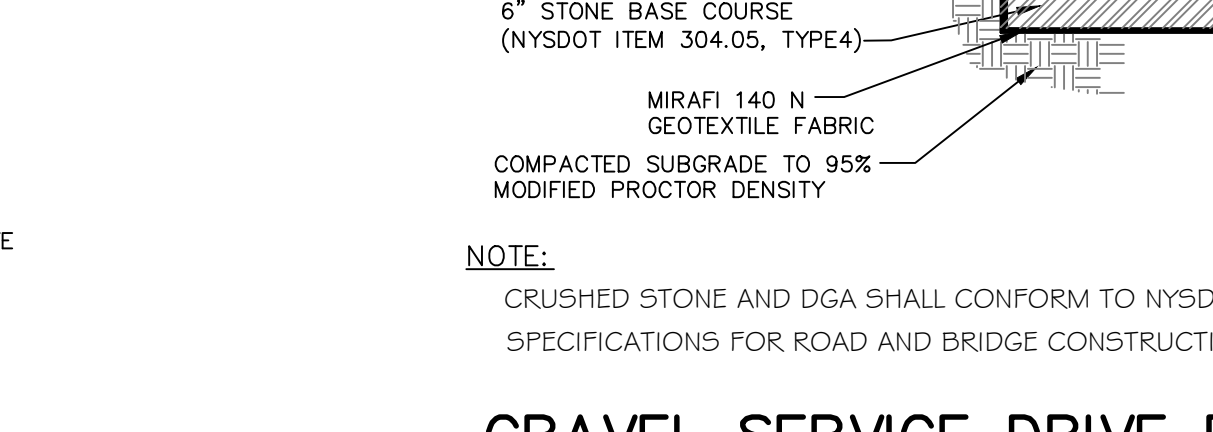

**CONCRETE CURB DETAIL**  
NOT TO SCALE



**BELGIAN BLOCK DEPRESSED CURB DETAIL AT DRIVEWAY**  
NOT TO SCALE

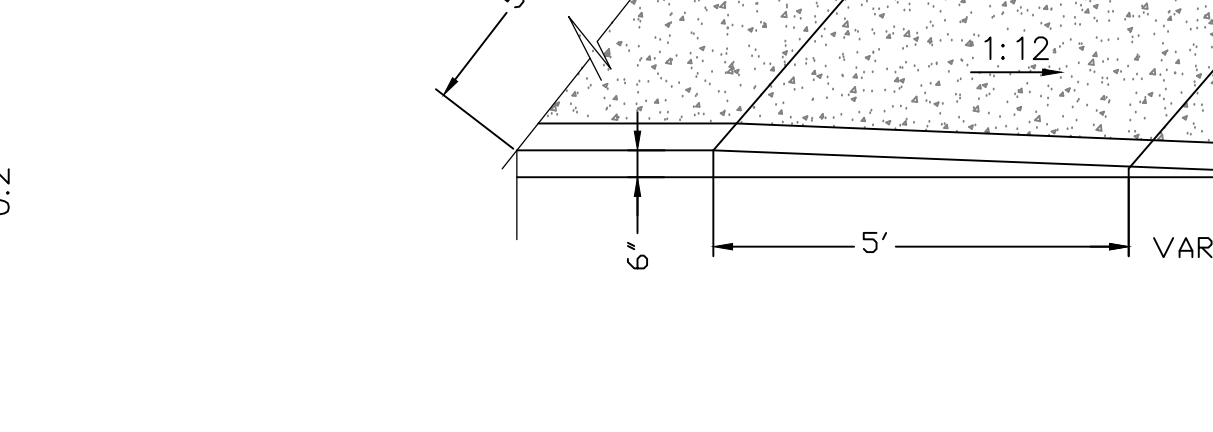

**HANDICAP STALL DETAIL**  
NOT TO SCALE



**PAVEMENT SECTION DETAIL**  
NOT TO SCALE

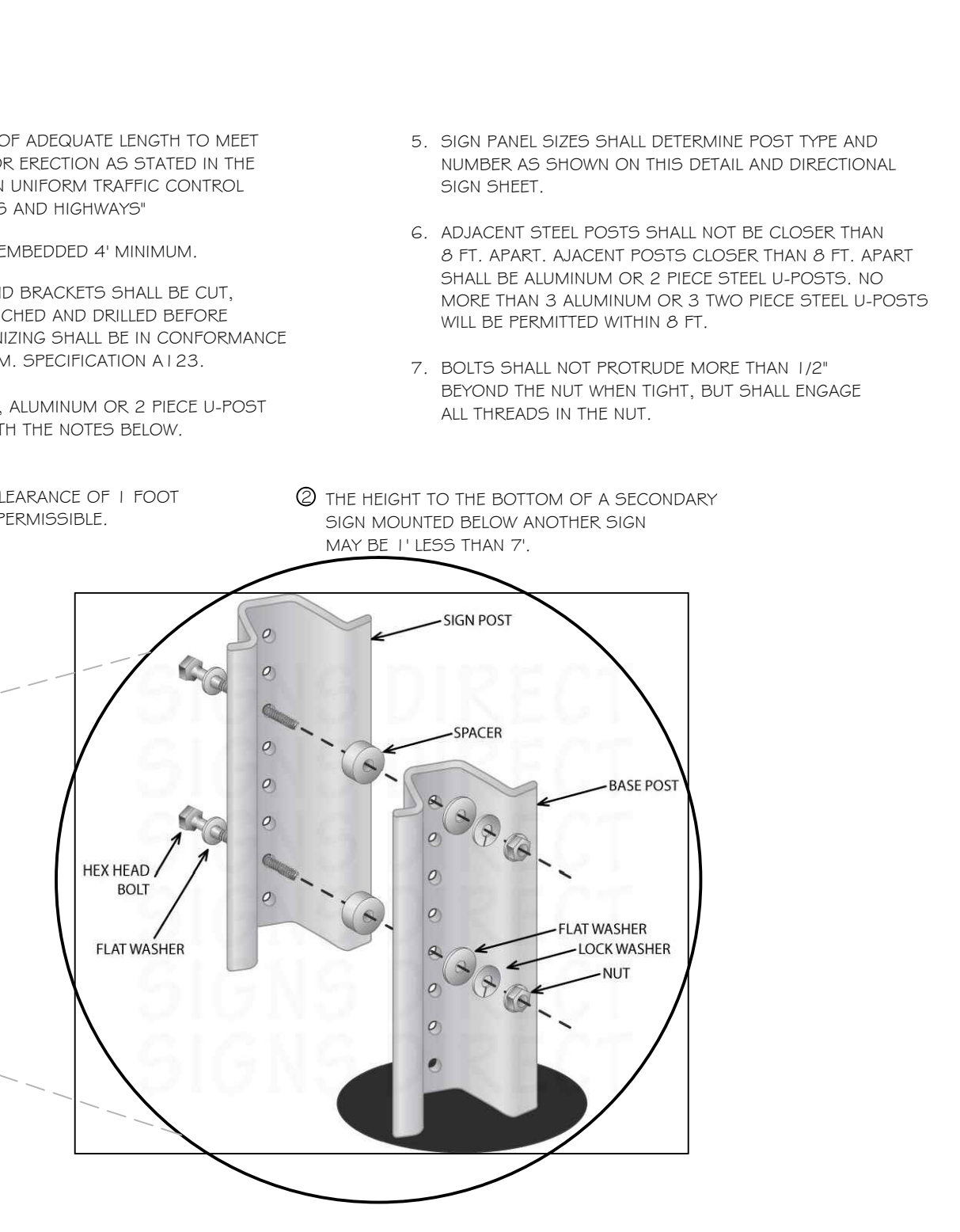

**SITE SIGNAGE**

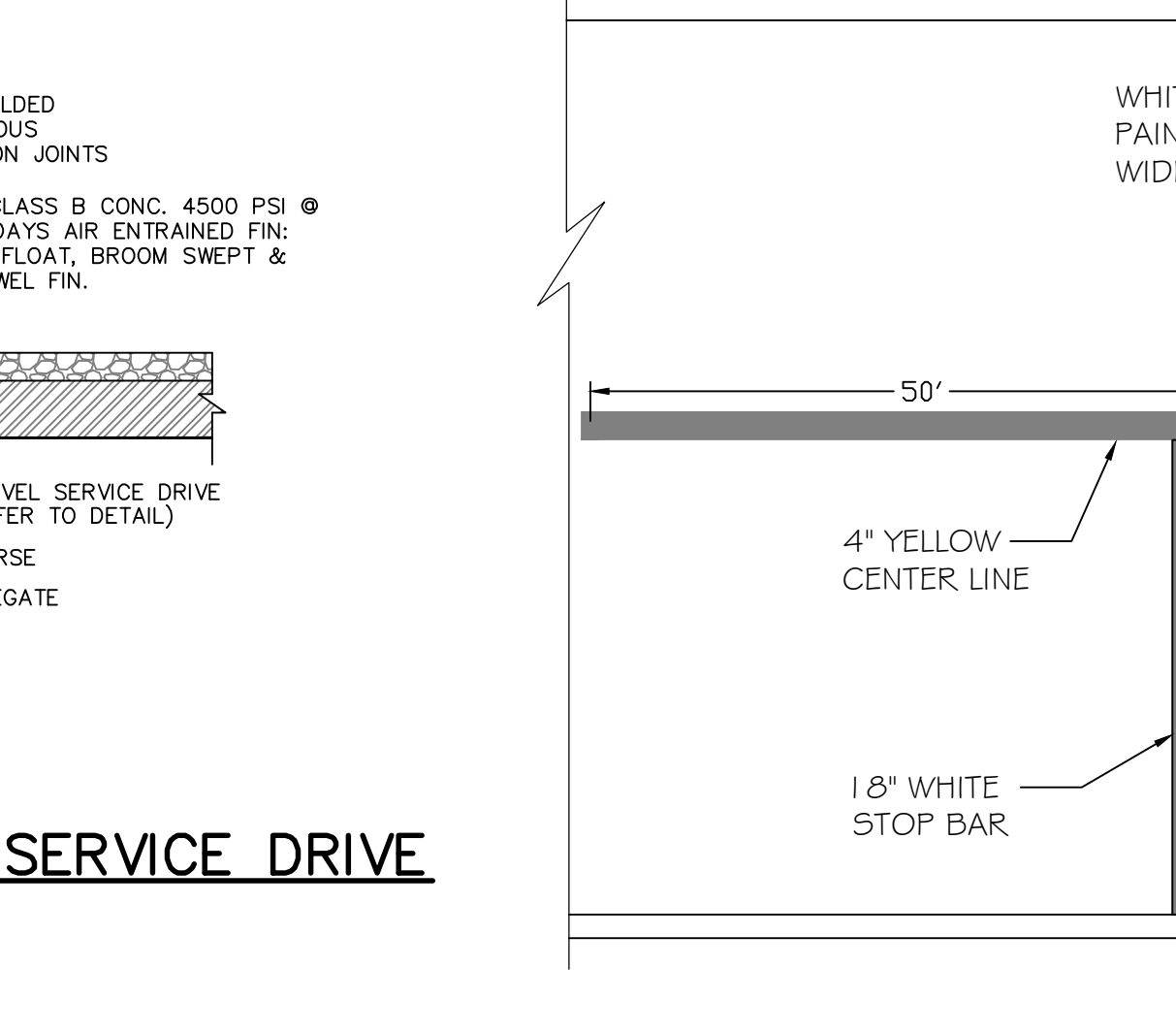

**4"x6"Wx12"L BELGIAN BLOCK CURB DETAIL**  
NOT TO SCALE



**PAVEMENT SECTION DETAIL**  
NOT TO SCALE

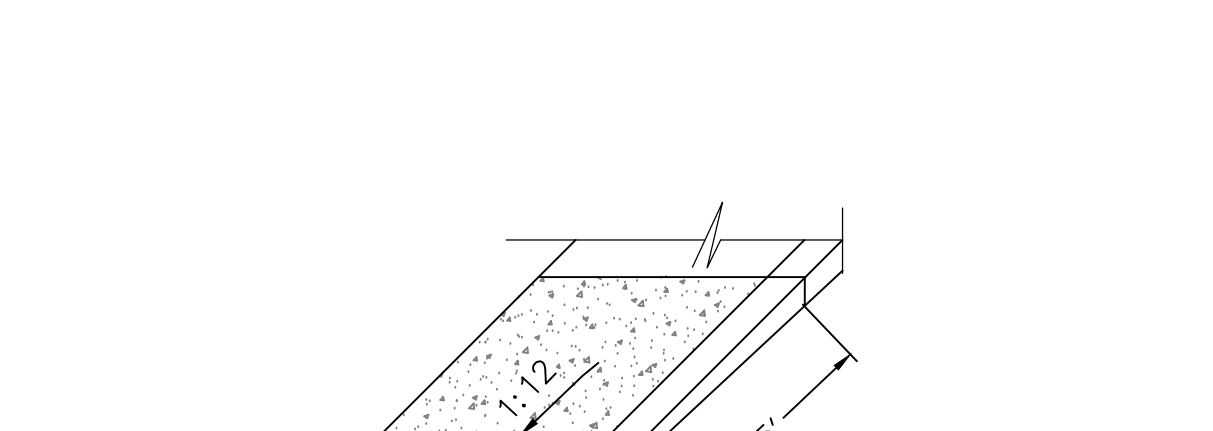

**SECTION A-A**

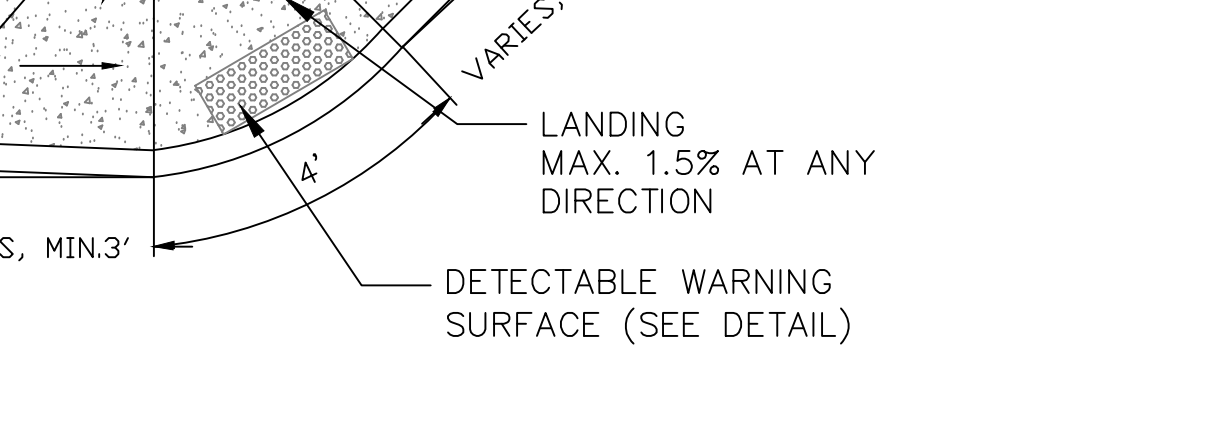

**CONCRETE CURB DETAIL**  
NOT TO SCALE

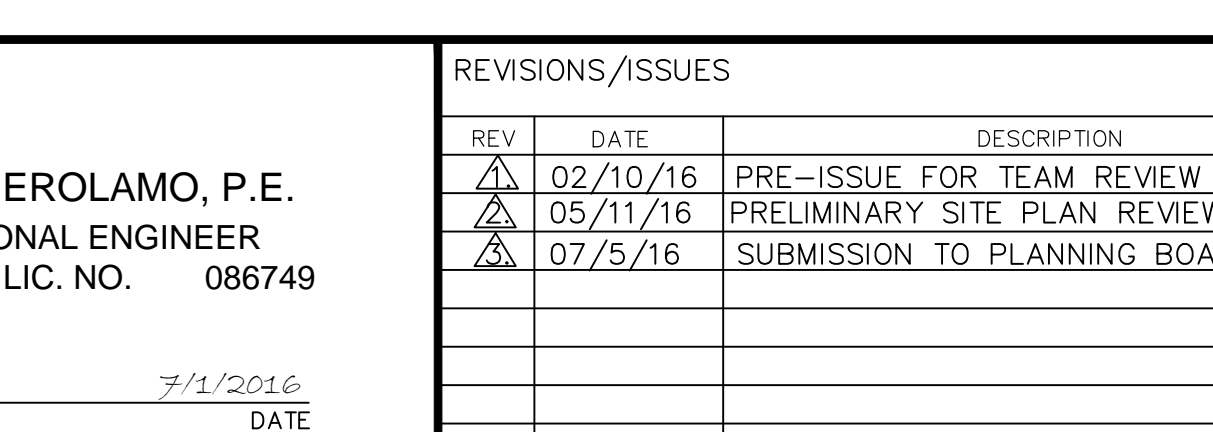

**BELGIAN BLOCK DEPRESSED CURB DETAIL AT DRIVEWAY**  
NOT TO SCALE

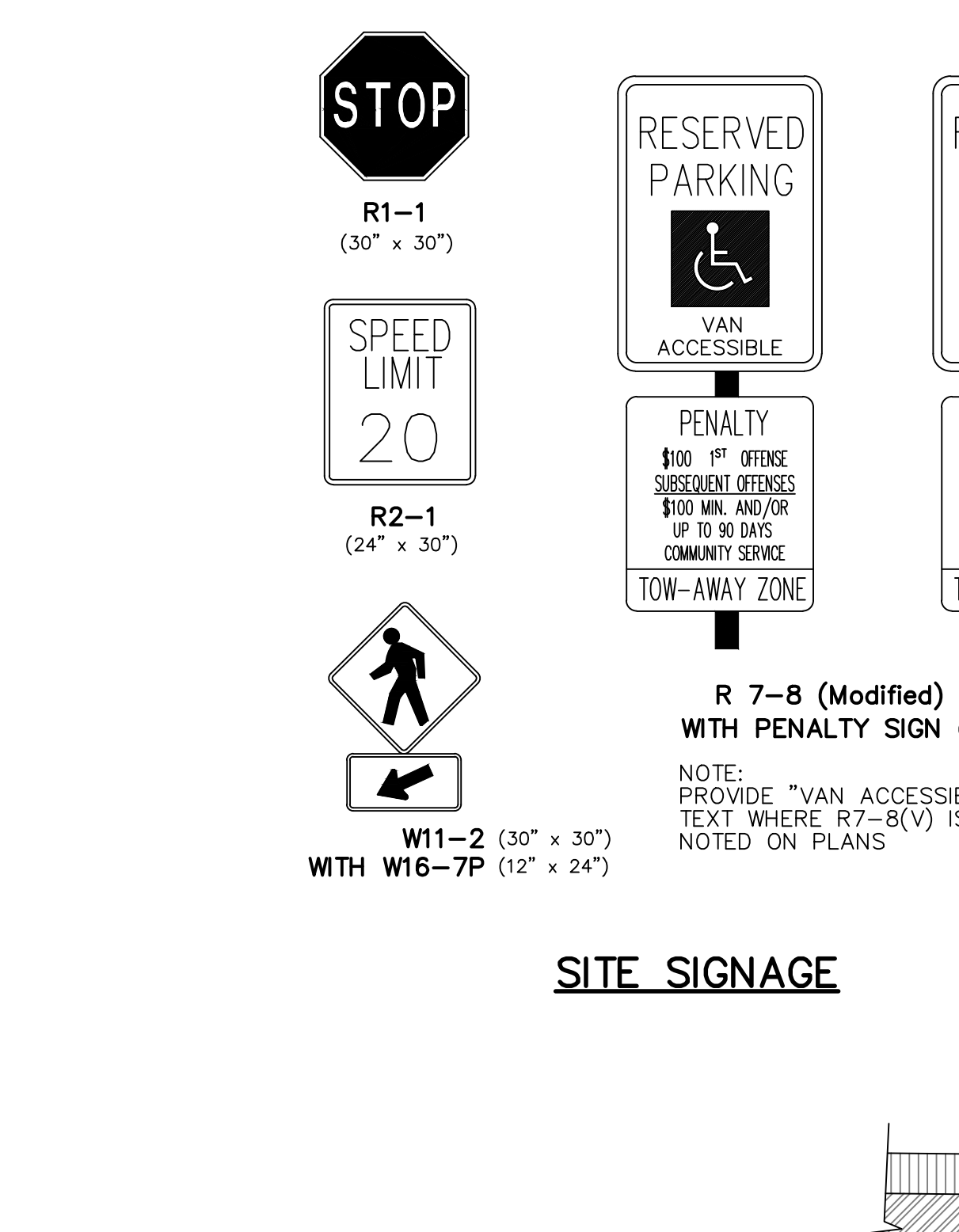

**HANDICAP MOUNTING SIGN DETAIL**  
NOT TO SCALE

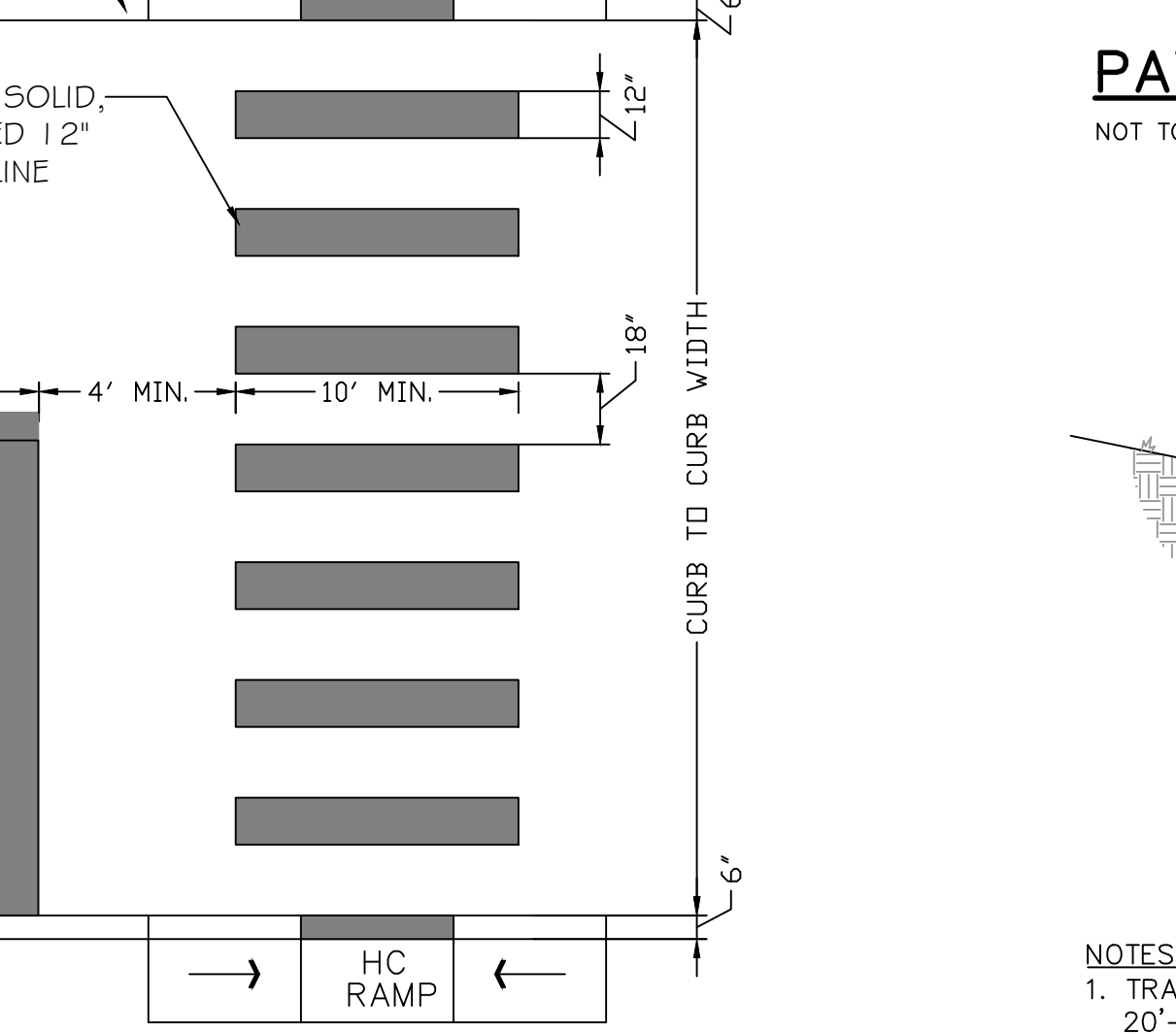

**CONCRETE WALK**  
NOT TO SCALE



**GRAVEL SERVICE DRIVE DETAIL**  
NOT TO SCALE



**DETECTABLE WARNING SURFACE DETAIL**  
NOT TO SCALE

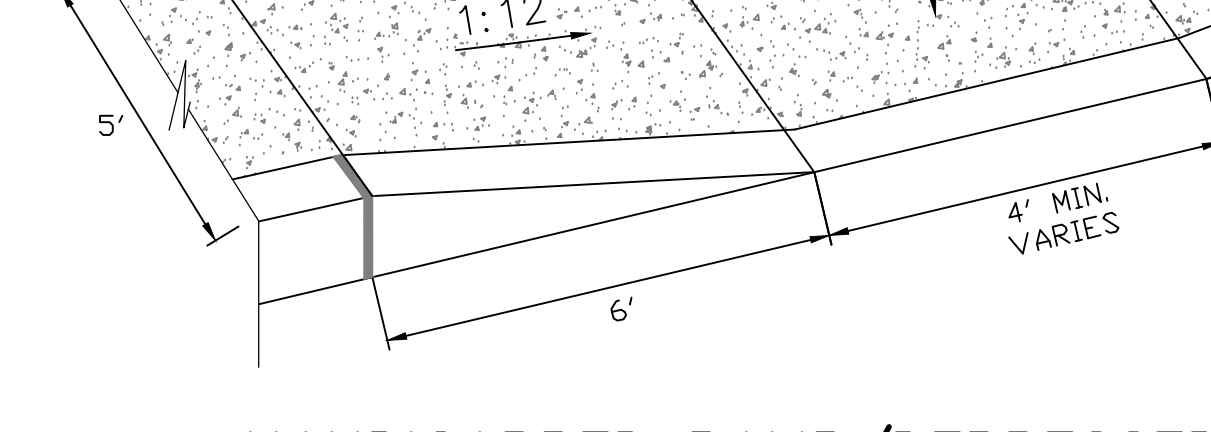

**HANDICAPPED RAMP DETAIL FOR CORNER OF SIDEWALK**  
NOT TO SCALE



**HANDICAPPED RAMP/DEPRESSED CURB DETAIL**  
NOT TO SCALE

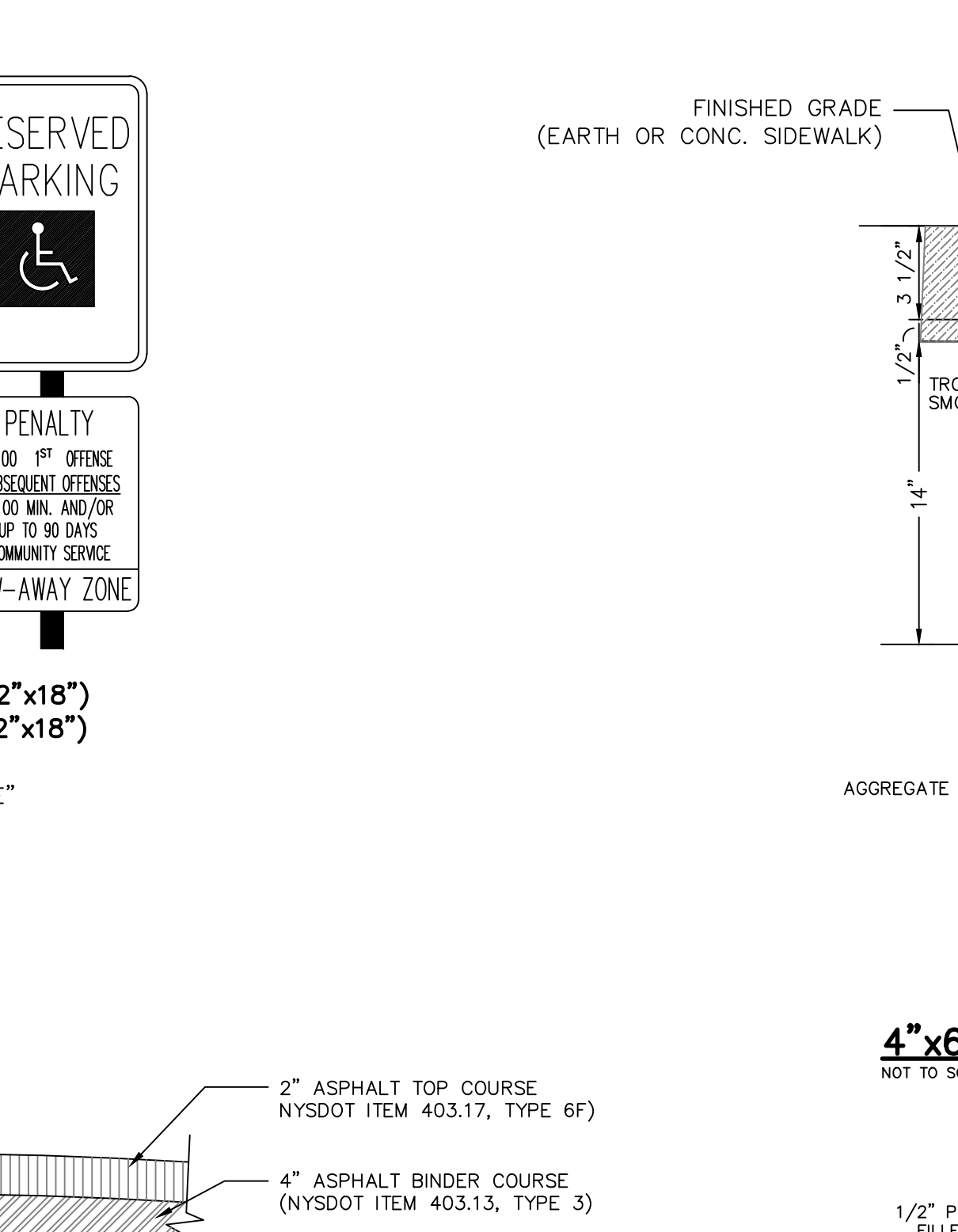

**SITE SIGNAGE**

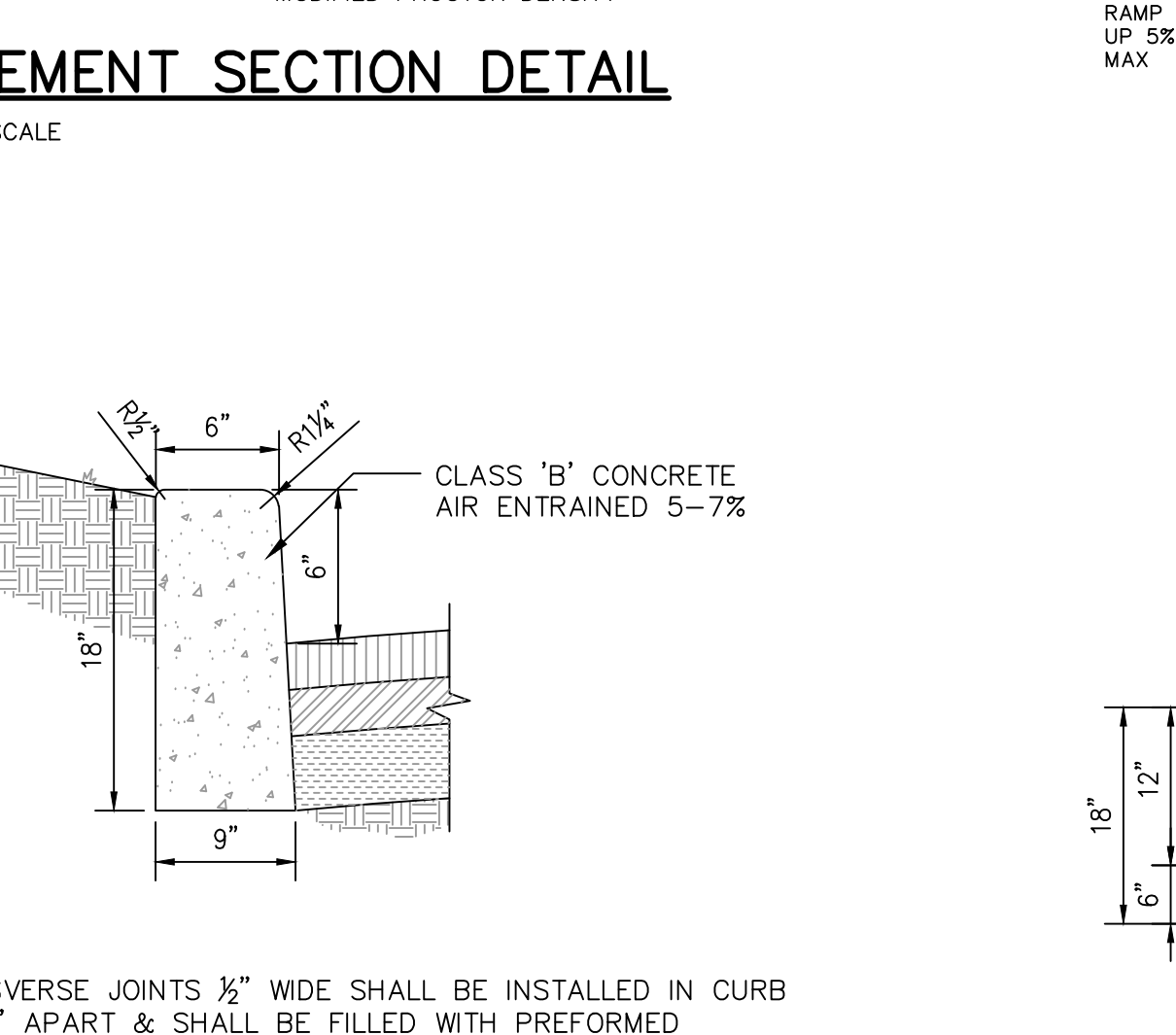

**4"x6"Wx12"L BELGIAN BLOCK CURB DETAIL**  
NOT TO SCALE

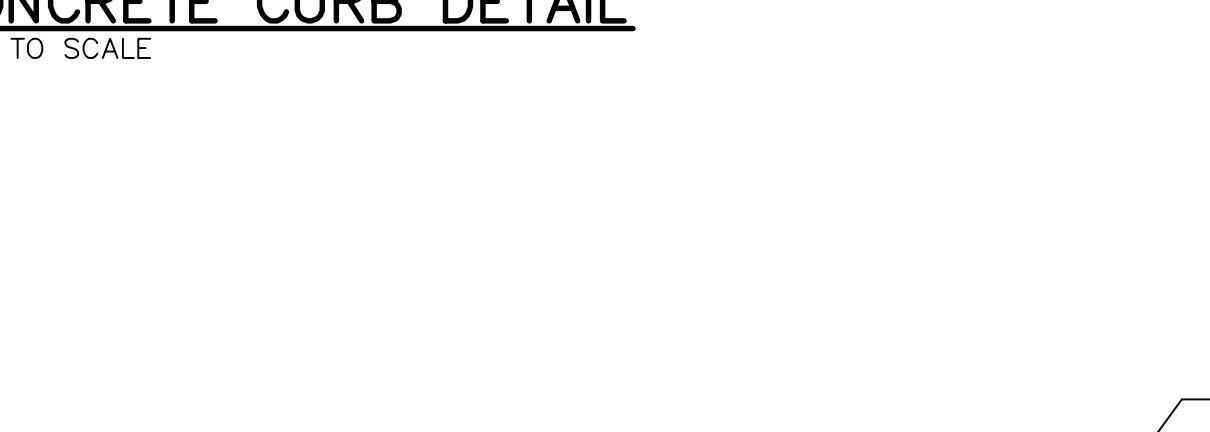

**PAVEMENT SECTION DETAIL**  
NOT TO SCALE



**SECTION A-A**

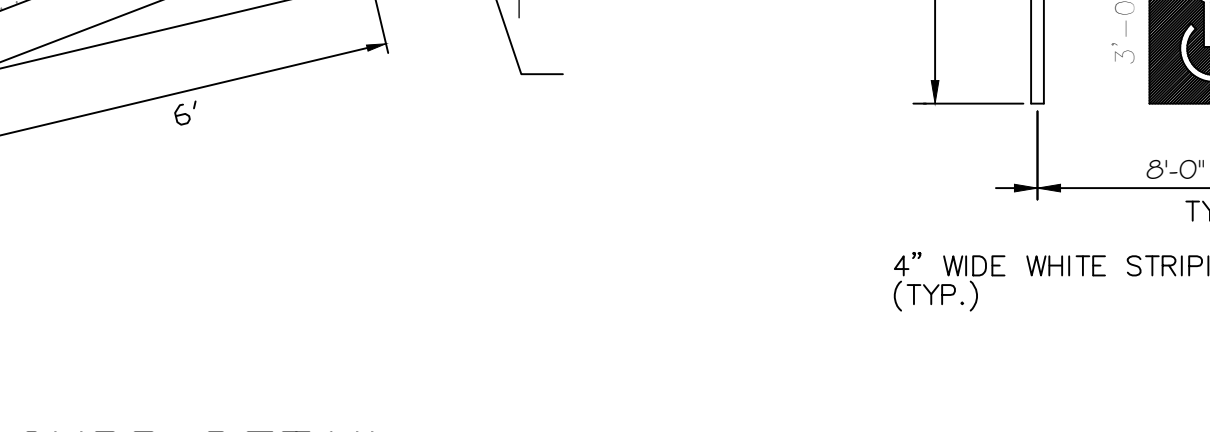

**CONCRETE CURB DETAIL**  
NOT TO SCALE

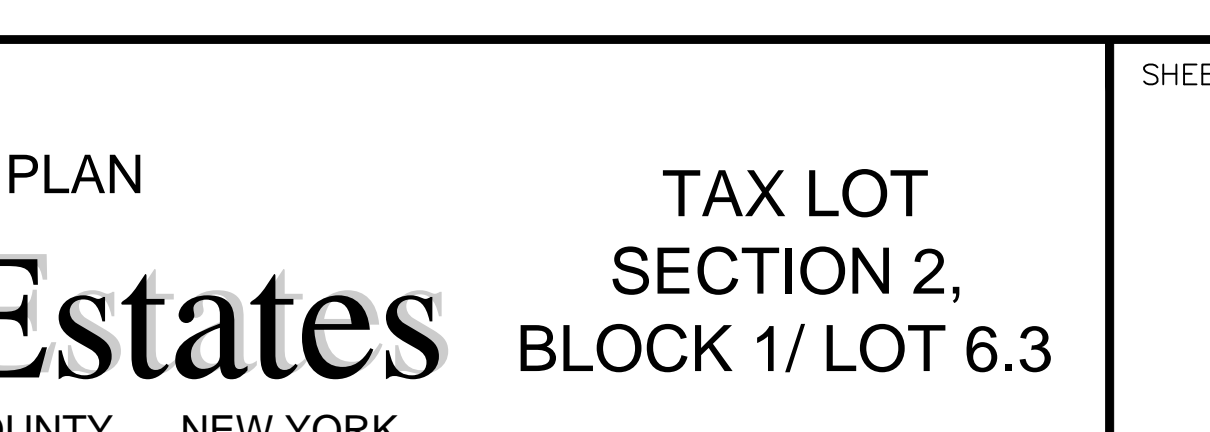

**BELGIAN BLOCK DEPRESSED CURB DETAIL AT DRIVEWAY**  
NOT TO SCALE

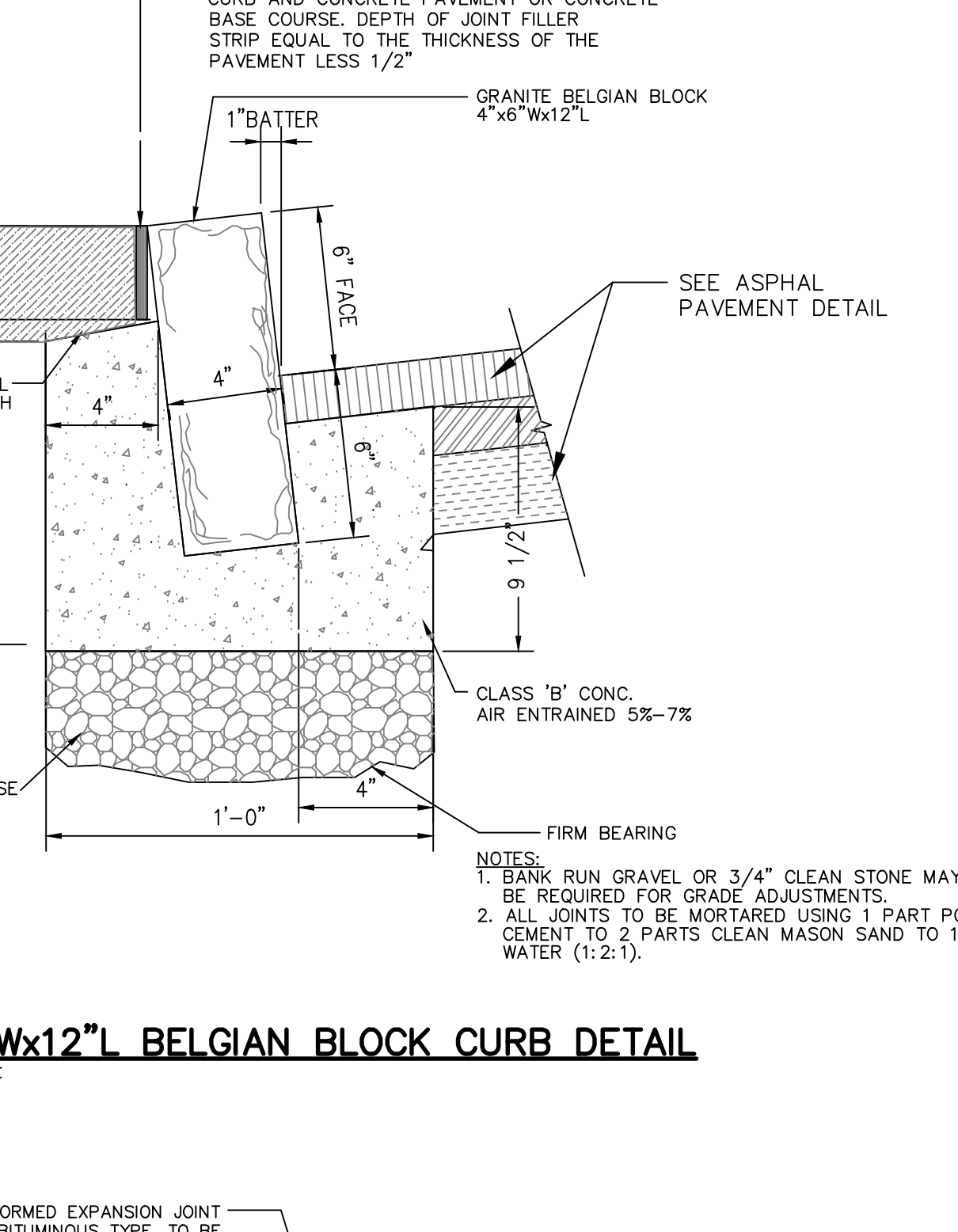

**HANDICAP MOUNTING SIGN DETAIL**  
NOT TO SCALE

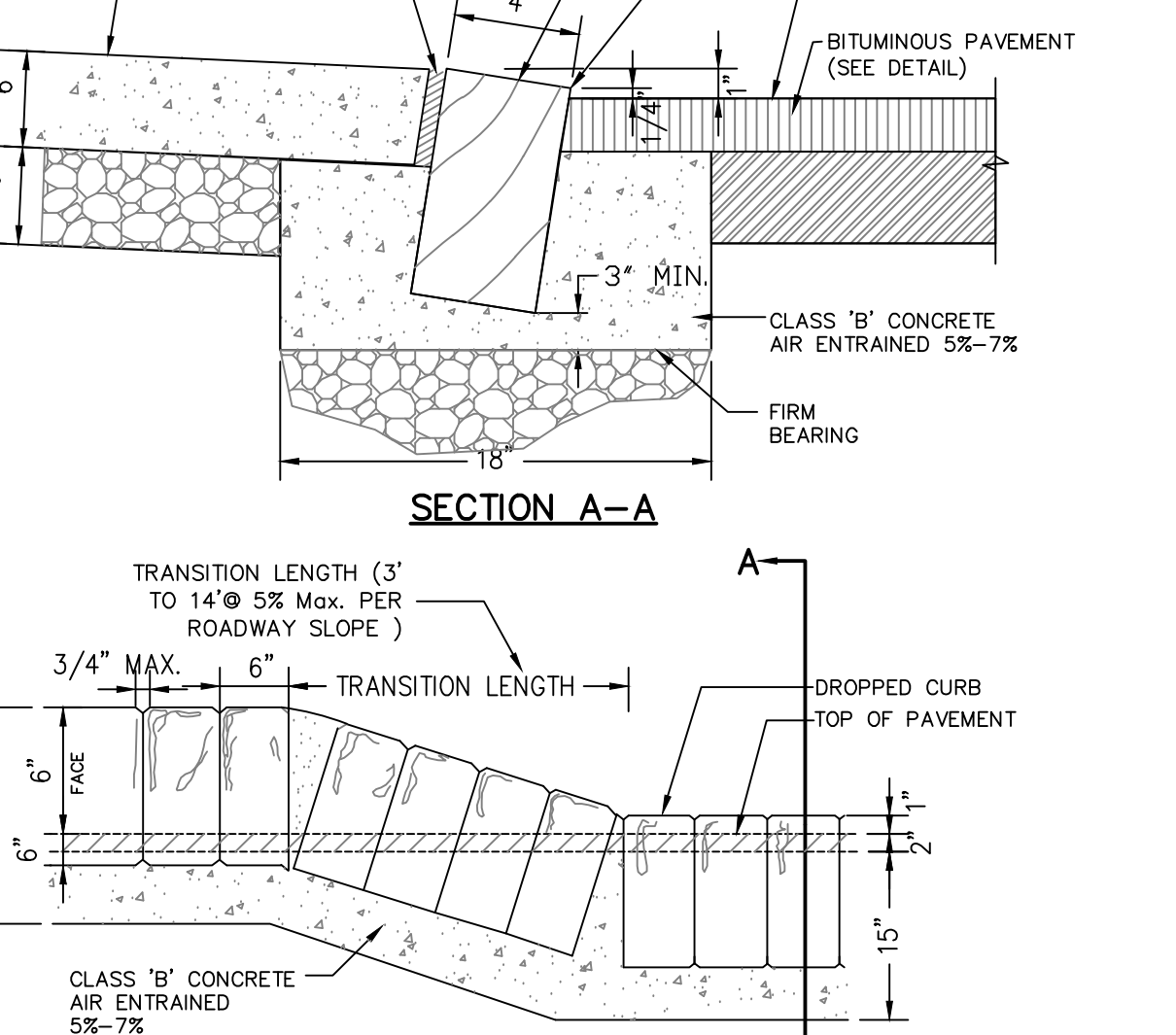

**CONCRETE WALK**  
NOT TO SCALE

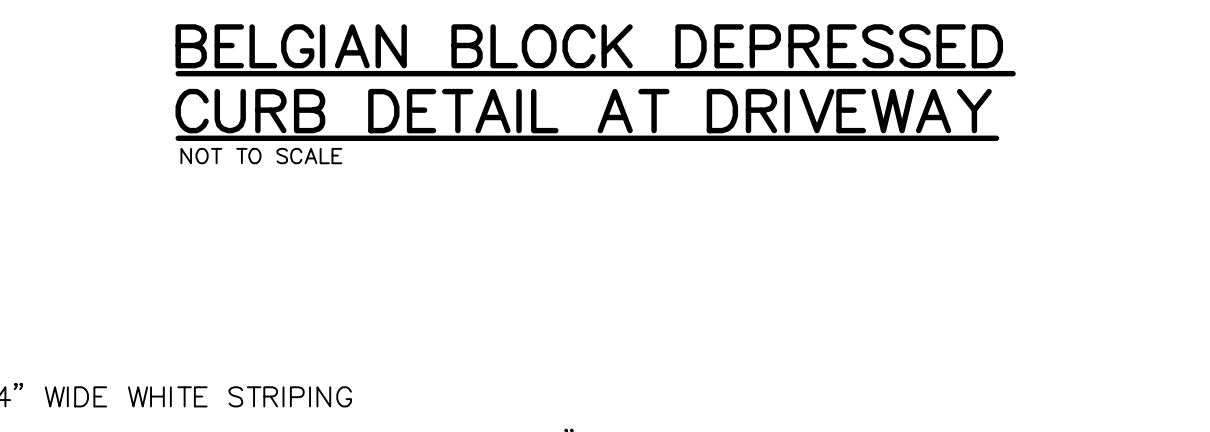

**GRAVEL SERVICE DRIVE DETAIL**  
NOT TO SCALE

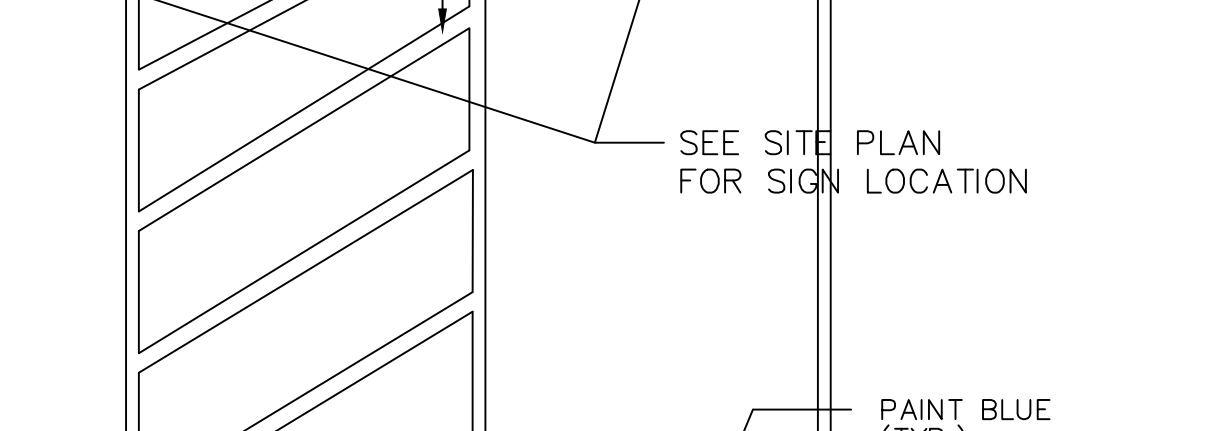

**DETECTABLE WARNING SURFACE DETAIL**  
NOT TO SCALE

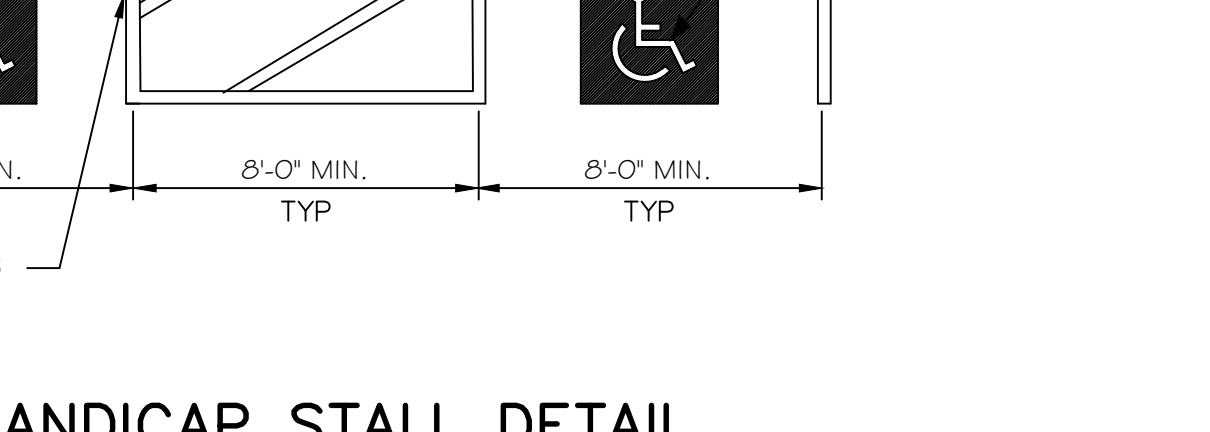

**HANDICAPPED RAMP DETAIL FOR CORNER OF SIDEWALK**  
NOT TO SCALE

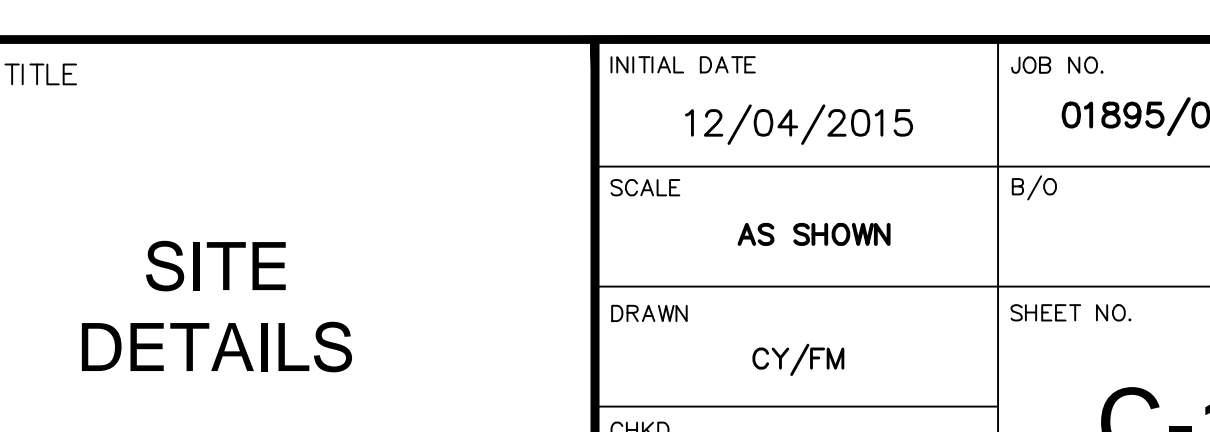

**HANDICAPPED RAMP/DEPRESSED CURB DETAIL**  
NOT TO SCALE

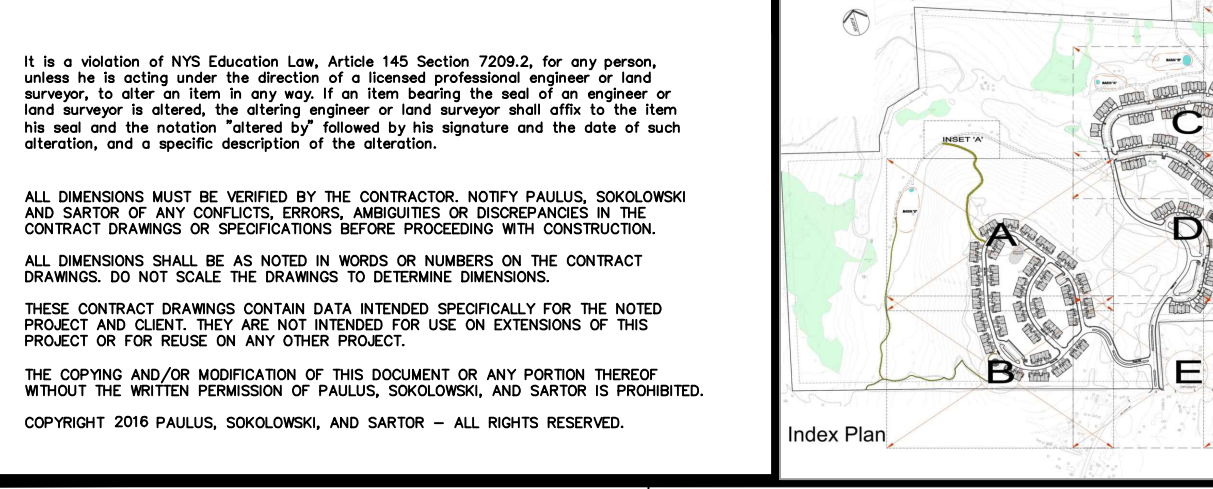

REV	DATE	DESCRIPTION
02/10/16	PRE-ISSUE FOR TEAM REVIEW	
05/11/16	PRELIMINARY SITE PLAN REVIEW	
07/5/16	SUBMISSION TO PLANNING BOARD	

REV	DATE	DESCRIPTION
02/10/16	PRE-ISSUE FOR TEAM REVIEW	
05/11/16	PRELIMINARY SITE PLAN REVIEW	
07/5/16	SUBMISSION TO PLANNING BOARD	

REV	DATE	DESCRIPTION
02/10/16	PRE-ISSUE FOR TEAM REVIEW	
05/11/16	PRELIMINARY SITE PLAN REVIEW	
07/5/16	SUBMISSION TO PLANNING BOARD	

REV	DATE	DESCRIPTION
02/10/16	PRE-ISSUE FOR TEAM REVIEW	
05/11/16	PRELIMINARY SITE PLAN REVIEW	
07/5/16	SUBMISSION TO PLANNING BOARD	